

Note! Disconnect the electric power to the machine!



Service Manual

Vegetable Preparation Machine RG-400i



Revision: 2018-06-13

Approved: Henrik Artursson

Note! Disconnect the electric power to the machine!

Table of contents

GENERAL	3
Installation, operation and cleaning.....	3
Tools.....	3
Lubrication and thread locking.....	3
Advice on thread lock (Loctite)	3
Accessories.....	4
Shaft sleeve and pins	5
Machine foot.....	6
Hinges.....	8
Chassis and wiring.....	10
Locking handle.....	13
Locking handle micro switch.....	15
Electric box	16
Speed knob	18
Buttons	20
Motor and lower gear box half.....	22
Upper gear box half.....	25
Bearing house and shaft.....	26
Micro switch unit.....	28
Knife chamber	32
SERVICE PROCEDURES AND ADJUSTMENTS.....	33
Function and safety test	33
Electrical safety tests	33
Electrical diagram	33
TROUBLESHOOTING	34

Note! Disconnect the electric power to the machine!

General

This service manual gives instructions for removal and replacement of parts including service procedures and adjustments for the vegetable preparation machine RG-400i.

This service manual is prepared for the use of trained service technicians and should not be used by those not properly qualified. It is not necessary to follow the exact order in this manual. Some steps can be taken before others if a particular object need to be serviced.

Installation, operation and cleaning

Refer to HALLDE User Manual.

Tools

- Standards set of hand tools
- Gear puller
- HALLDE wrench part number 1184 for removal of decoring screw

Lubrication and thread locking

- Loctite 243, 2701 and activator 7649
- Oil for lubrication of gear box
- Food grade grease for lubricating seal washer
- Mineral oil for lubricating push feeder and hinges

Advice on thread lock (Loctite)

It is strongly recommended to let Loctite 243 cure for at least 12 hours before the machine is taken in service. If used in combination with Loctite activator 7649 (read the instruction before use) the cure time is decreased dramatically and should have cured completely within an hour. Always wipe off any excess fluid. For maximum strength thread lock like 2701 can be used instead of 243. However, it's recommended to apply type according to this manual. It could otherwise make service attempts unnecessary difficult. We recommend that the screw is heated to 250-300° C / 482-572 F° before any attempt to remove it. Use a heat gun and focus the heat to the screw not to damage surrounding parts that cannot handle the temperature.

Note! Disconnect the electric power to the machine!

Removal and replacement of parts

Accessories

1. Remove any detachable accessories as feed cylinder and ergo loop from the machine base.



Note! Disconnect the electric power to the machine!

Shaft sleeve and pins

1. Preheat the lock screw to 300° C before Undoing. Once unscrewed push the big carrier pin out from either side. Heat up the smaller carrier pins, undo and remove the sleeve.

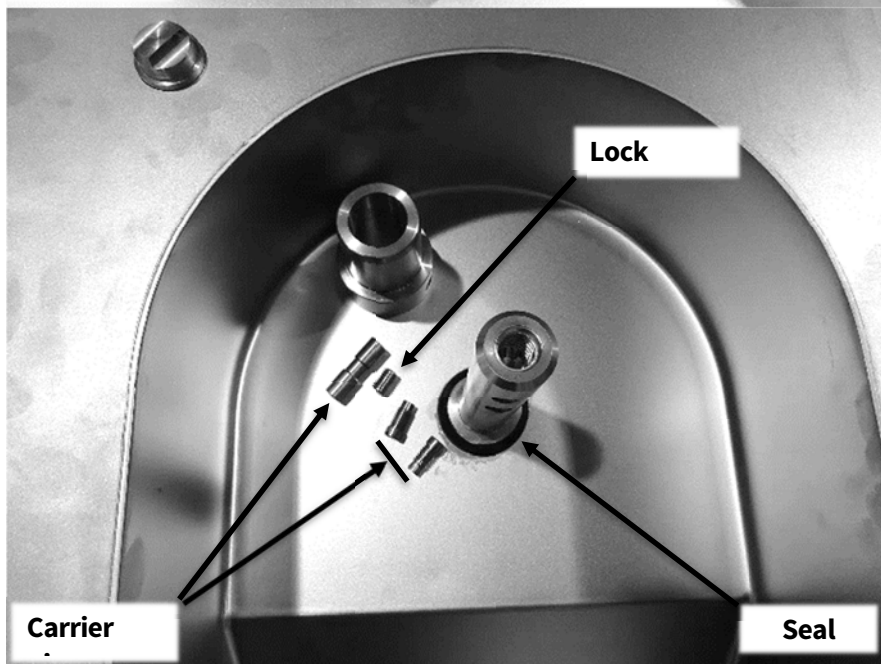
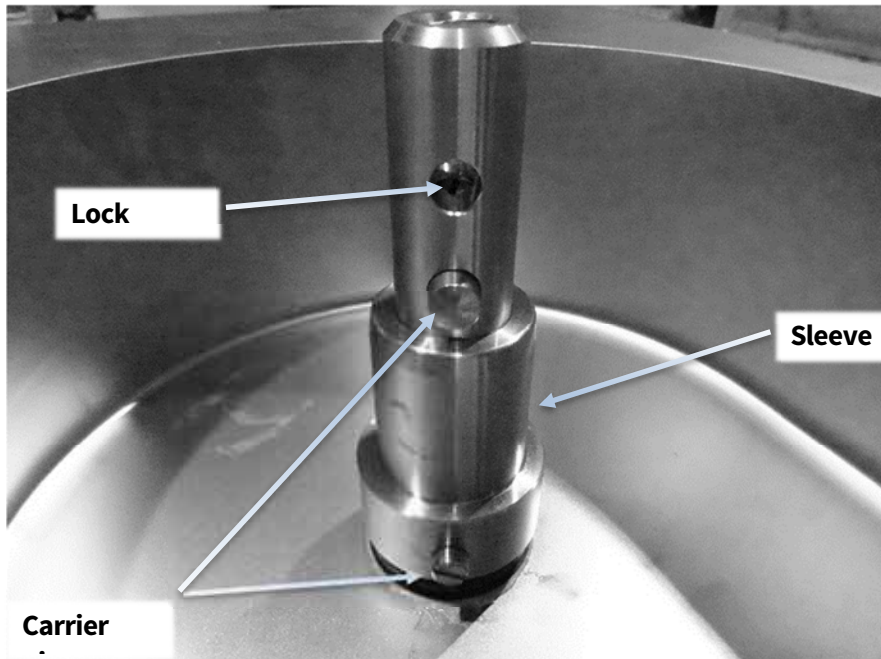

Mount the parts in reversed order. The two smaller carrier pins must be aligned with the holes in the shaft. The bigger carrier pin should be set symmetric to the shaft. The seal ring should be lubricated with food grade grease. For best result use Loctite 7649 then 2701 when refastening the screws. Leave it to harden according to recommendations in this manual. Always wipe off any excess fluid.

Note! Disconnect the electric power to the machine!

Machine foot

1. Depending on what kind of working stand is at hand the handle may have to be removed before any further disassembling. Undo the three slotted screw holding the hinge to the base. These screws are locked with Loctite 243 and a torque of ~6 Nm.

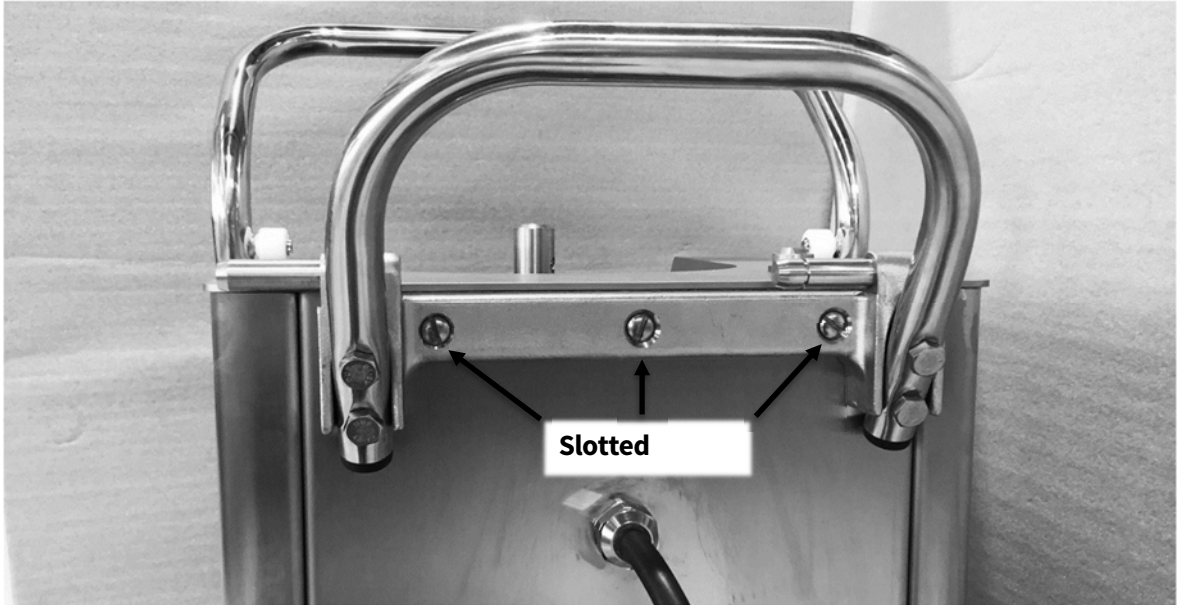

Note! Disconnect the electric power to the machine!

1. Turn the machine upside down on a suitable working stand with space for the shaft.

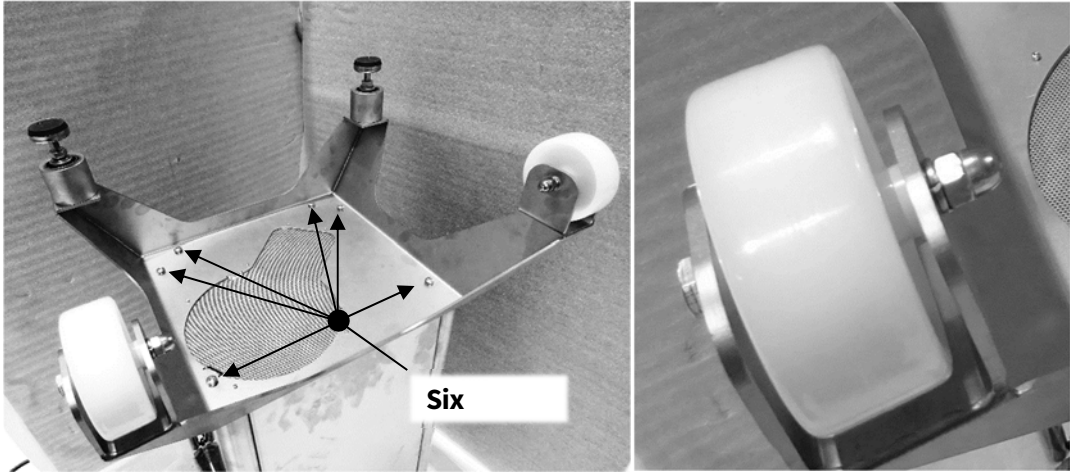

2. Dismantle the two wheels and the two feet. Then remove the six screws holding the whole foot.

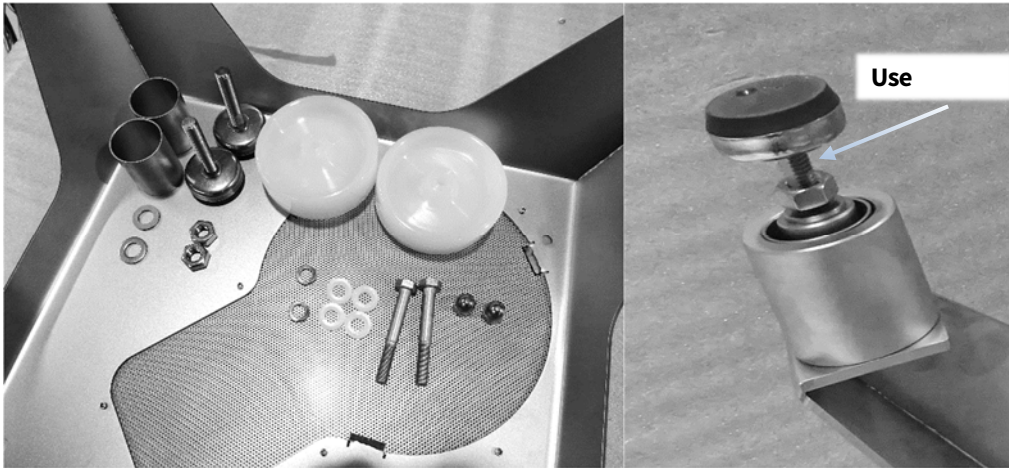

Reassemble in reversed order. The 6 screws that hold the foot is locked with a torque of ~6 Nm.

Note! Disconnect the electric power to the machine!

Hinges

1. Undo the cable retention so that the cable can slide freely. When reassembling leave some slack inside the machine before tightening the retention.



2. If you didn't remove the hinge on the backside now is the time to do so. Undo the three slotted screws. These screws are locked with Loctite 243 and a torque of ~6 Nm.



Note! Disconnect the electric power to the machine!

3. Completely disassembled.

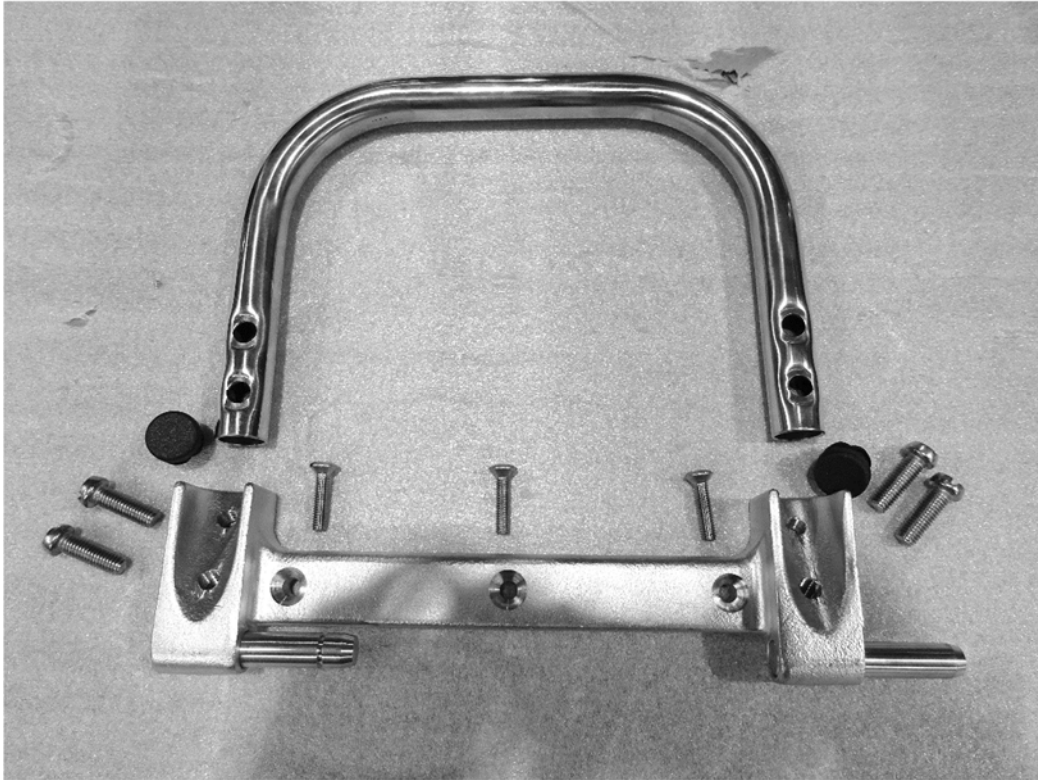

Reassemble in reversed order.

Note! Disconnect the electric power to the machine!

Chassis and wiring

1. Undo the screws that the back side is hooked on. These are locked with Loctite 243. Then unhook the backside.

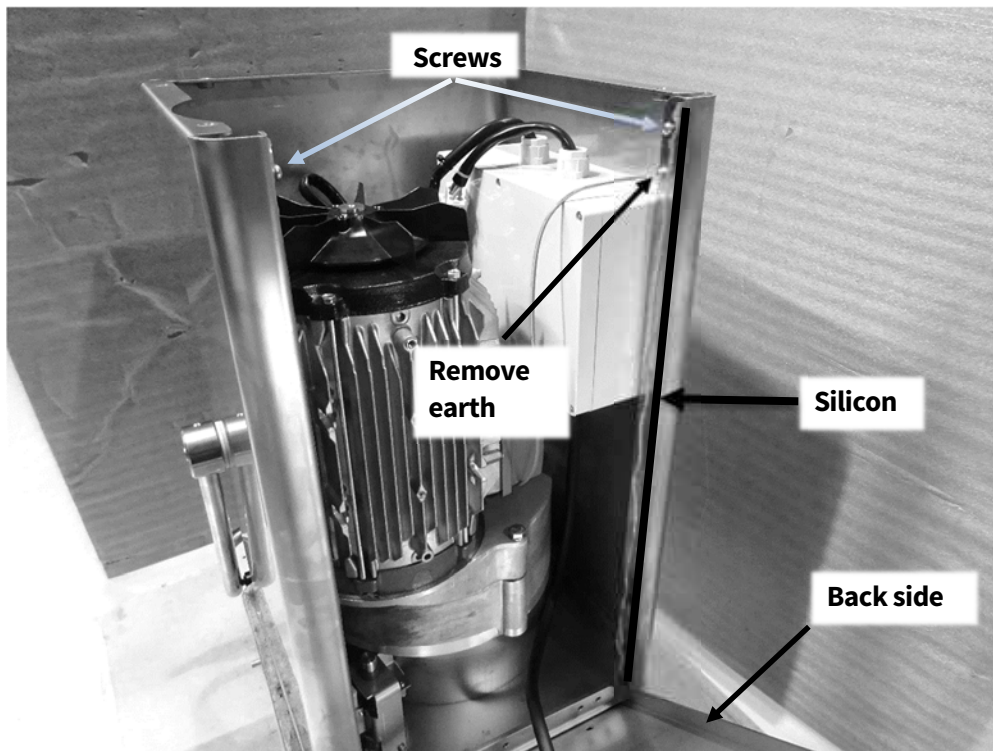

2. The back side is sealed with silicone on both sides.



Note! Disconnect the electric power to the machine!

3. Unplug all quick connections. There are three of them. Cut all zip-ties.

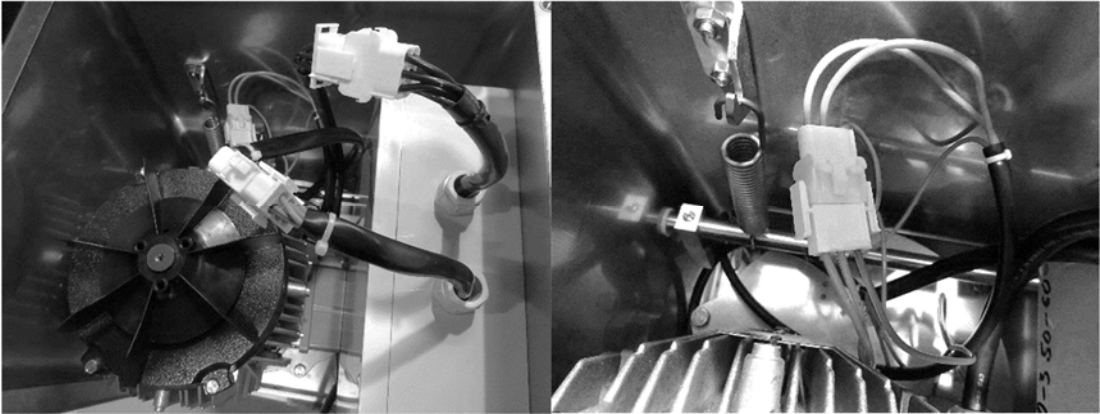

4. Unplug both wires to the micro switch. Leave the ground cable as it is.



Note! Disconnect the electric power to the machine!

5. Undo the four slotted screws holding the chassis to the top. These are locked with Loctite 243 and a torque of 6 Nm. Use the proper tool size to avoid scratching the chassis.

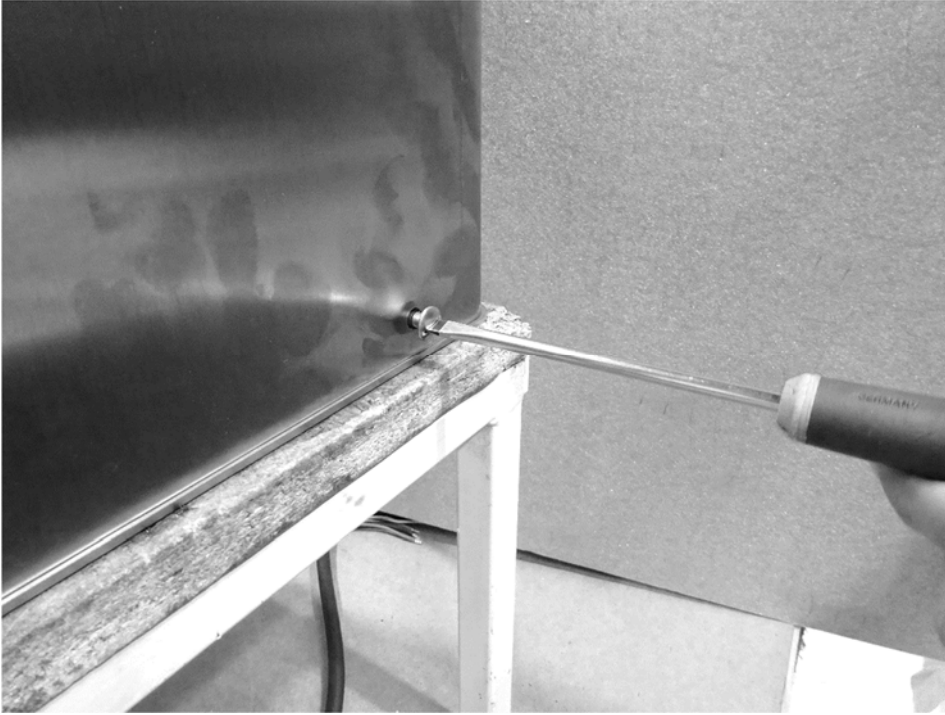

6. Make sure the wires are untangled. The chassis can now be lifted off the machine.

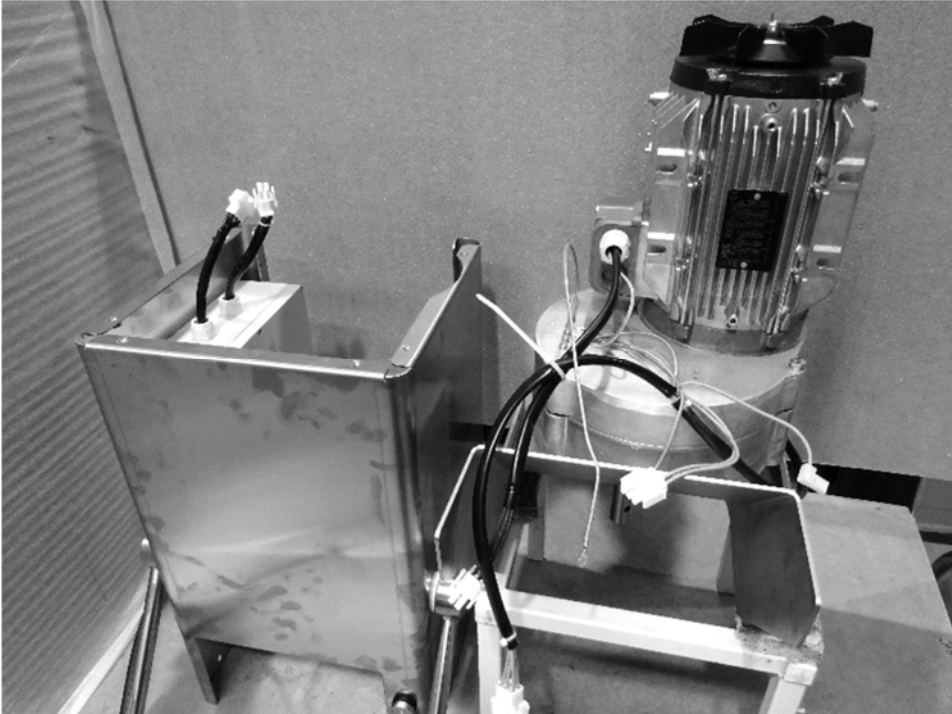

Reassemble in reversed order. The chassis fits in the slot that goes around the ejection. Inspect the gap between the chassis and knife chamber. The recommendation is to turn the 4 slotted screws so they barely touch the chassis and then have one person sitting on the unit while the 4 slotted screws are tightened. This to assure minimal gap between the knife chamber and chassis. Preferably this should be done when the machine is on its feet. Reapply some silicone to the back side if necessary.

Note! Disconnect the electric power to the machine!

Locking handle

1. In the chassis, remove the connections to the switch including the earth wire. Use pliers to lift the springs off the shaft. The shaft is lubricated where the spring attaches on the shaft.

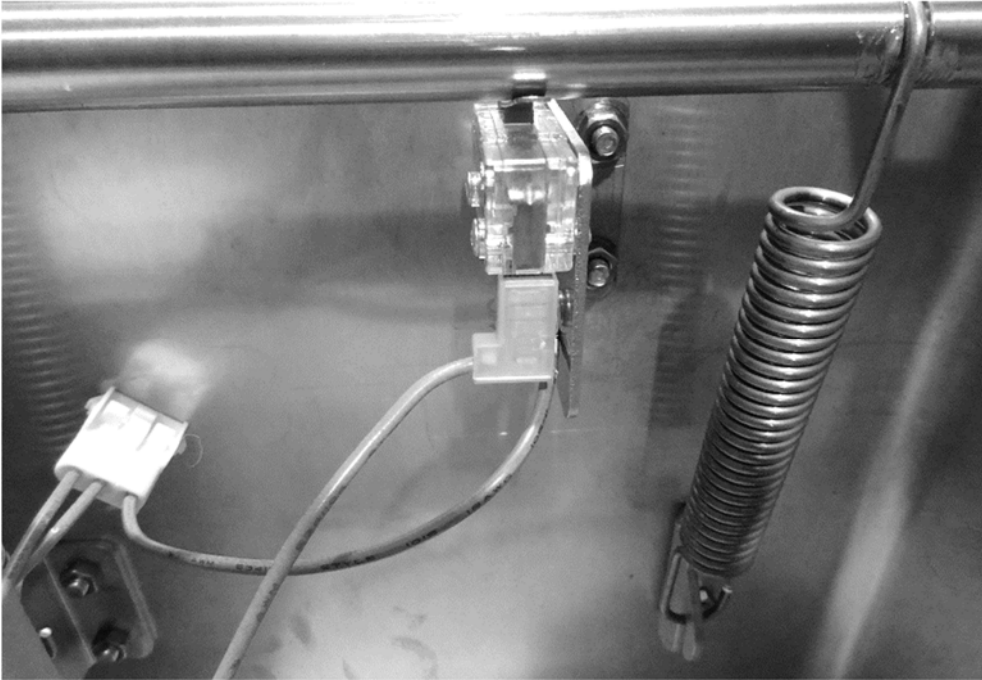

2. Remove the screw holding the stopper in place. Locked with Loctite 243. There is a hole cut out in the shaft for correct alignment of the stopper. Face the bevelled side against the chassis.

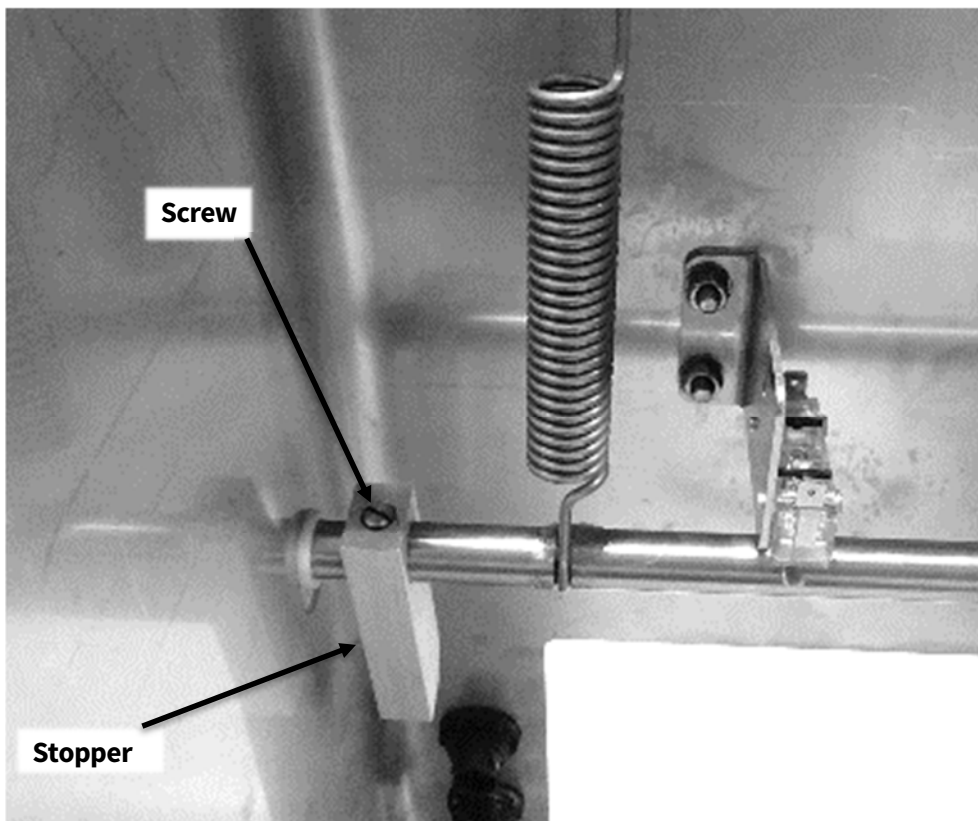

Note! Disconnect the electric power to the machine!

3. Undo the two screws holding the lock handle to the shaft. One on each side. The screws are locked with Loctite 243. There are two holes on each side of the shaft to which the screws align. From the inside, push the rod to one side so that it can be grabbed from the outside and pulled free. The complete lock handle can now be taken off the chassis.

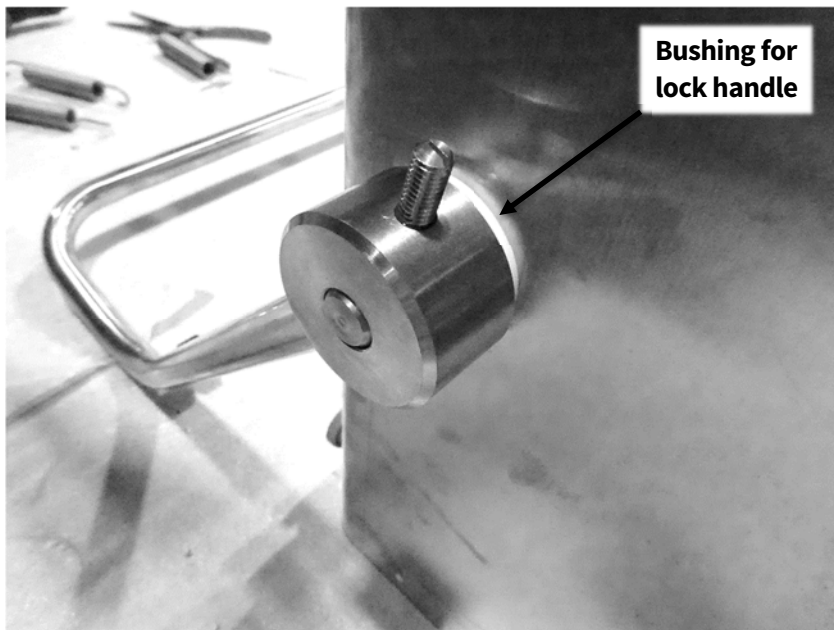

4. Disassembled locking handle.

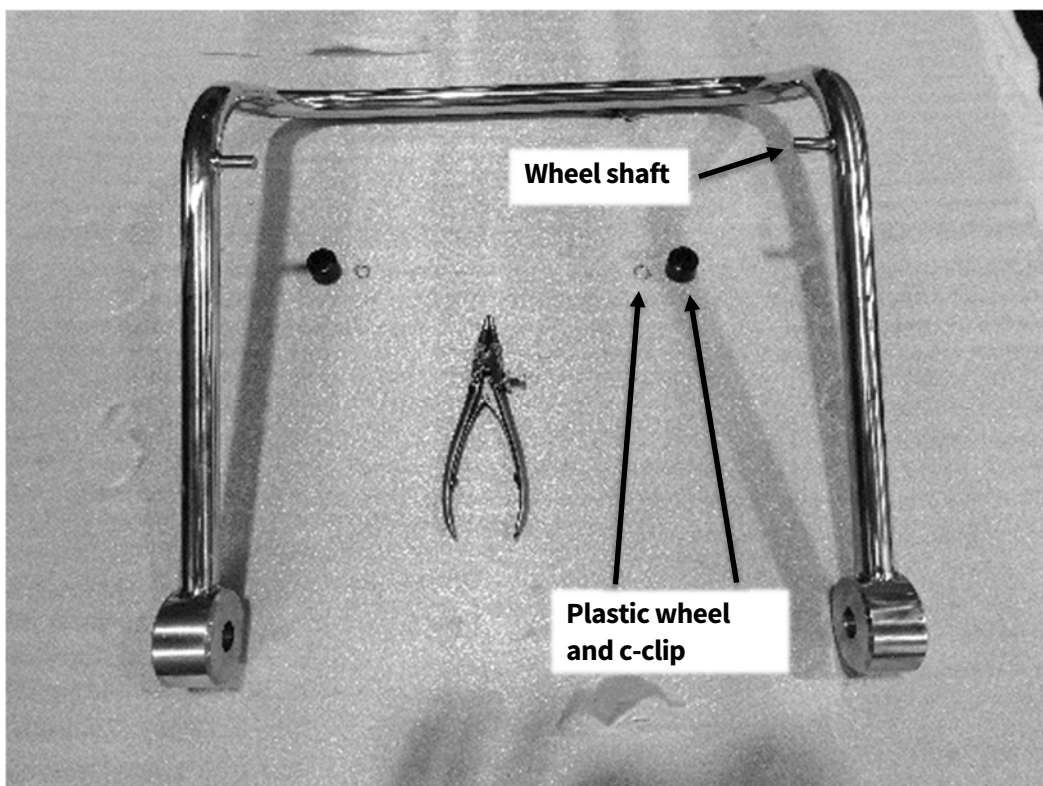

Note! Disconnect the electric power to the machine!

Locking handle micro switch

1. The micro switch attached to the chassis is riveted to the bracket. In case it needs to be replaced remove the bracket and grind the rivets flat to the bracket and push them out. Replace the micro switch and fasten with new **aluminium** rivets. Use Loctite 243 on the nuts holding the bracket.

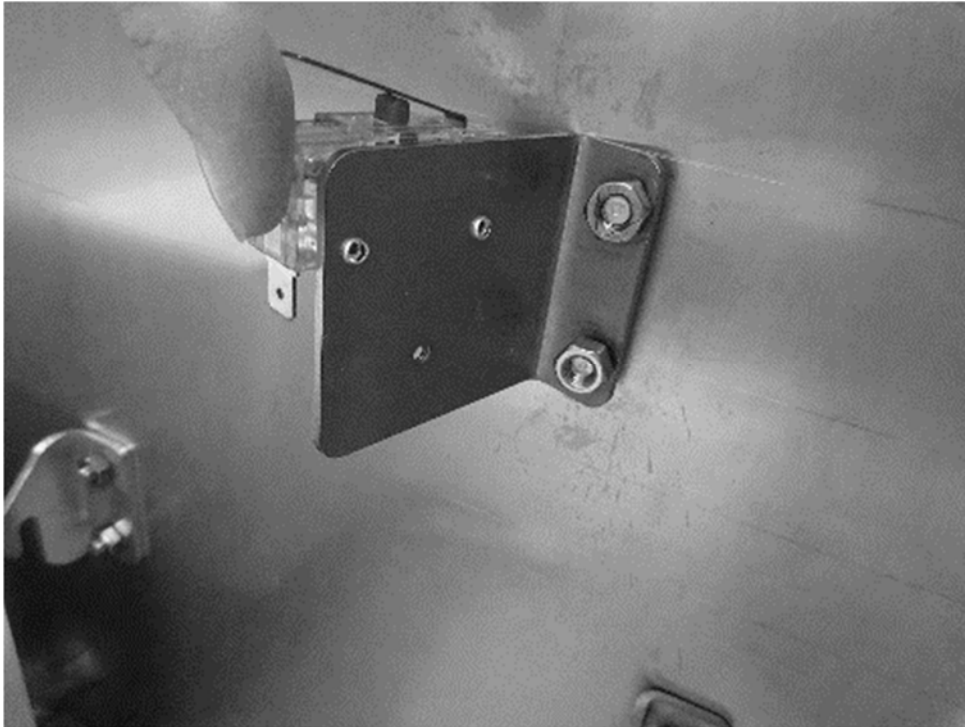

If the bracket has been moved make sure the handle (shaft) actuates the switch correctly. Assure that the contact points in the switch is clearly separated. Failure to do so could cause intermittent stops and danger to the user.

Note! Disconnect the electric power to the machine!

Electric box

1. Remove the electric box by undoing the two slotted screws on the outside of the chassis. Be ready to catch the box from the inside.

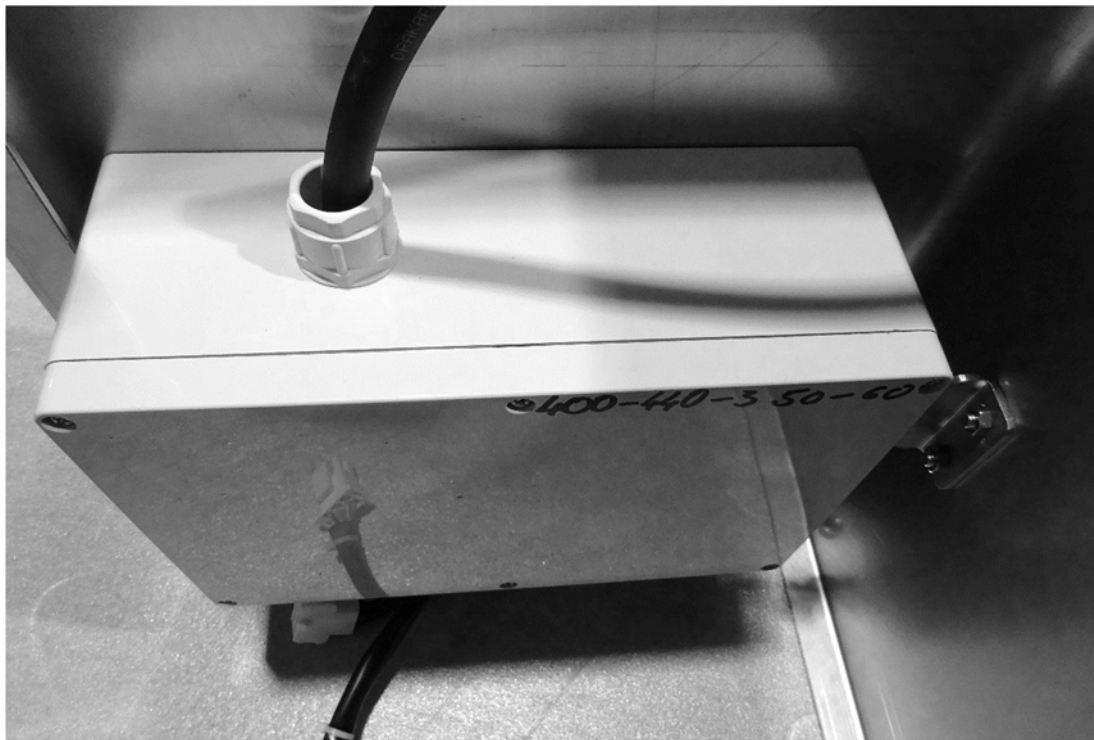
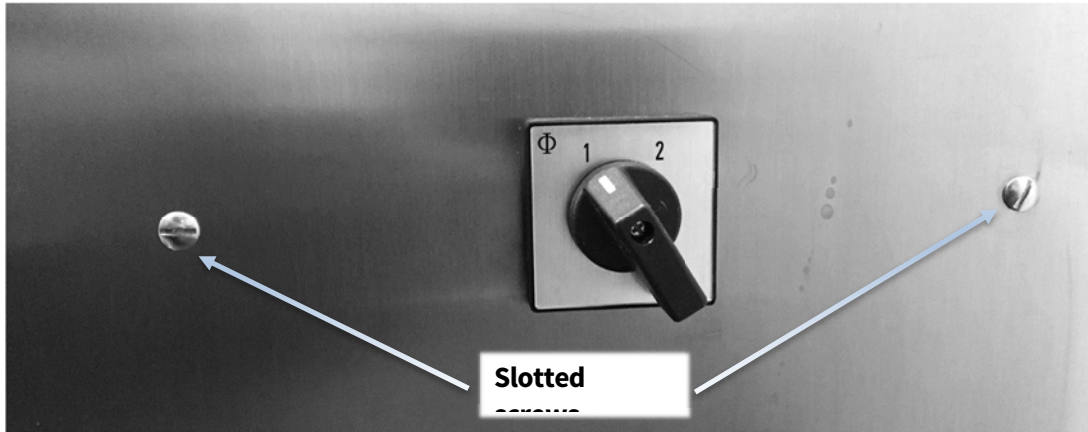

The box can be serviced by removing the screws on the outside with only the foot removed.

Note! Disconnect the electric power to the machine!

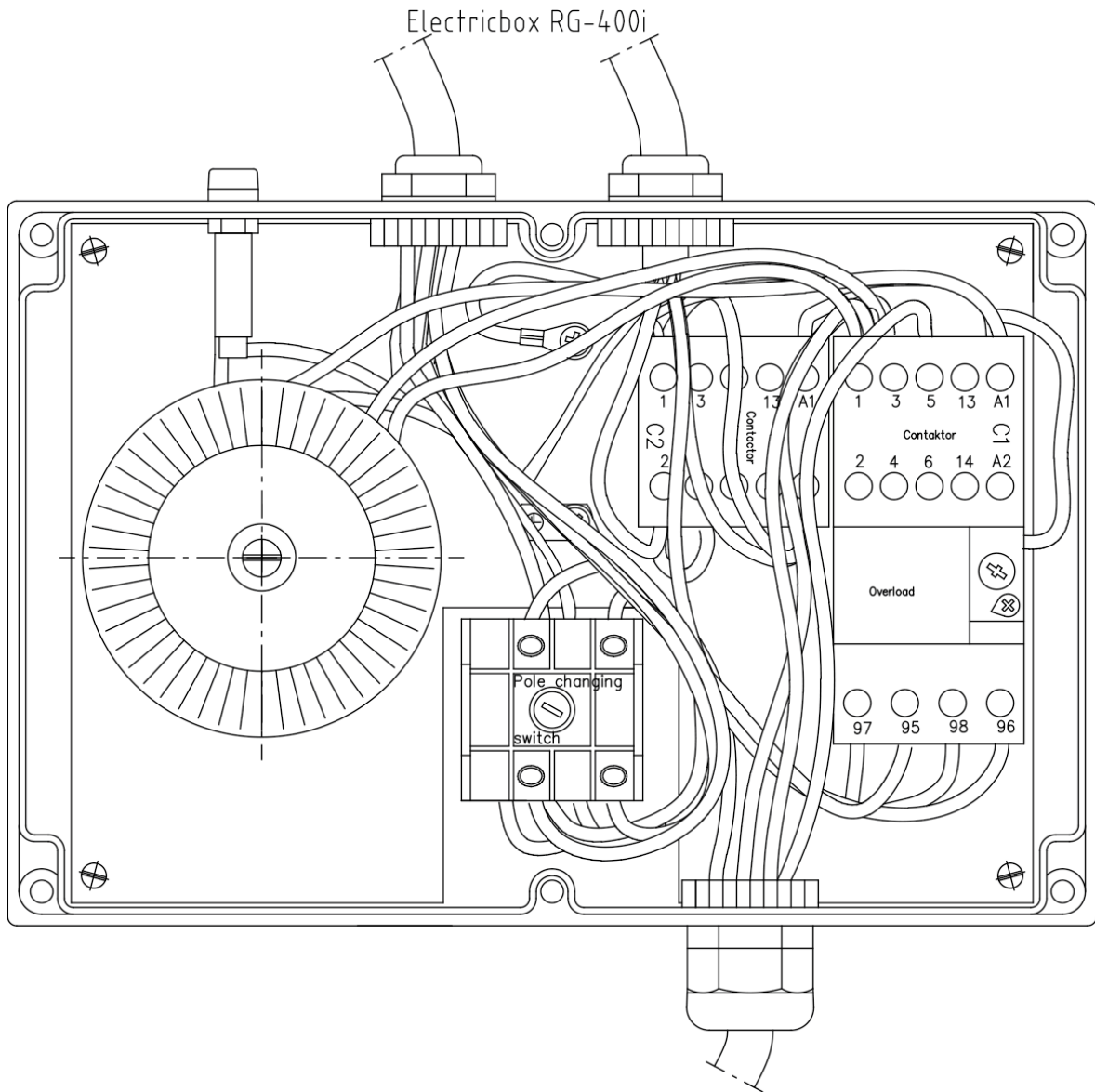

Note! Disconnect the electric power to the machine!

Speed knob

1. Disassemble the knob by removing the screw in the centre of the knob. To remove the shaft inside the knob the electric box needs to be removed.



2. Remove the cover by inserting a blade between the frame and the cover.



Note! Disconnect the electric power to the machine!

3. Remove the two screws holding the frame to the chassis. Behind the frame is a seal to prevent water from entering through the hole.

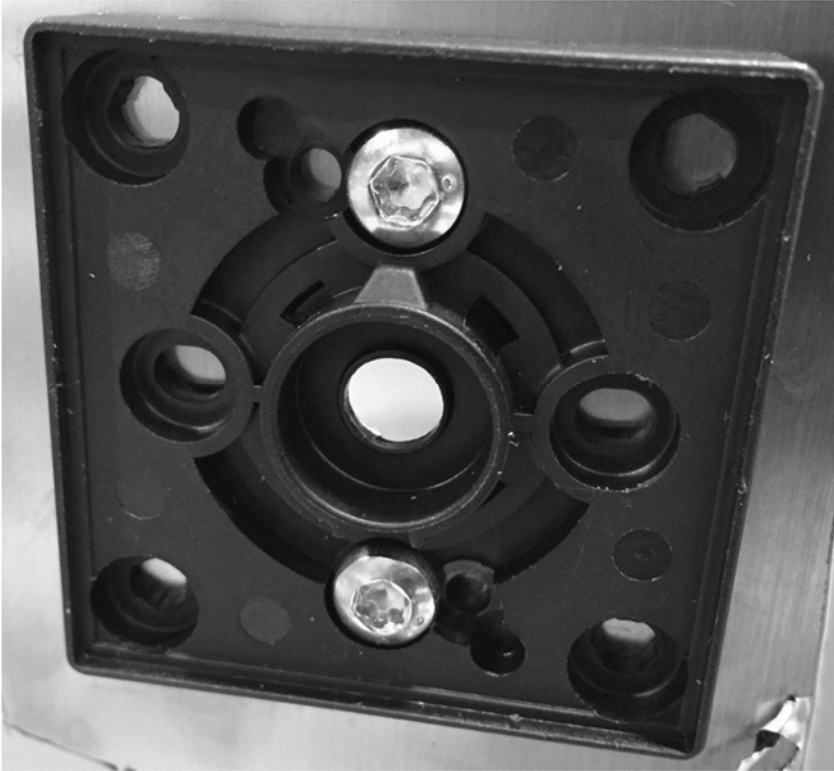

4. The complete assembly looks like this disassembled.

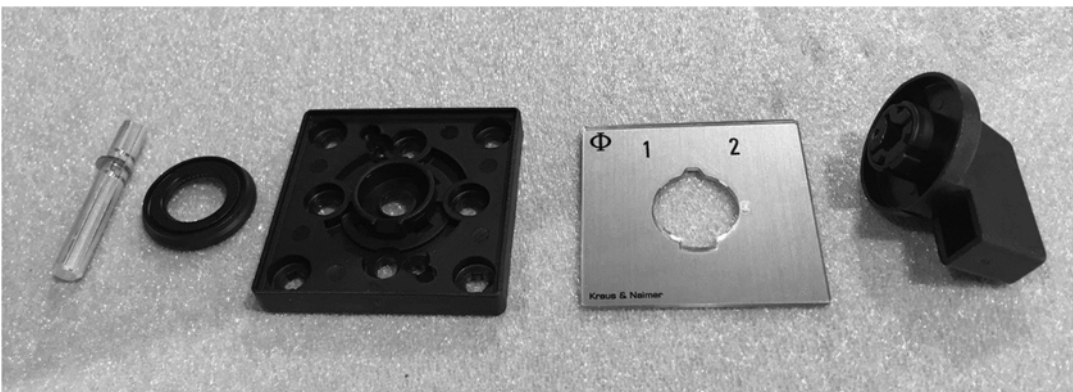

Reassemble in reversed order.

Note! Disconnect the electric power to the machine!

Buttons

1. Disconnect the button mechanisms by pushing the lock to open (off) position.

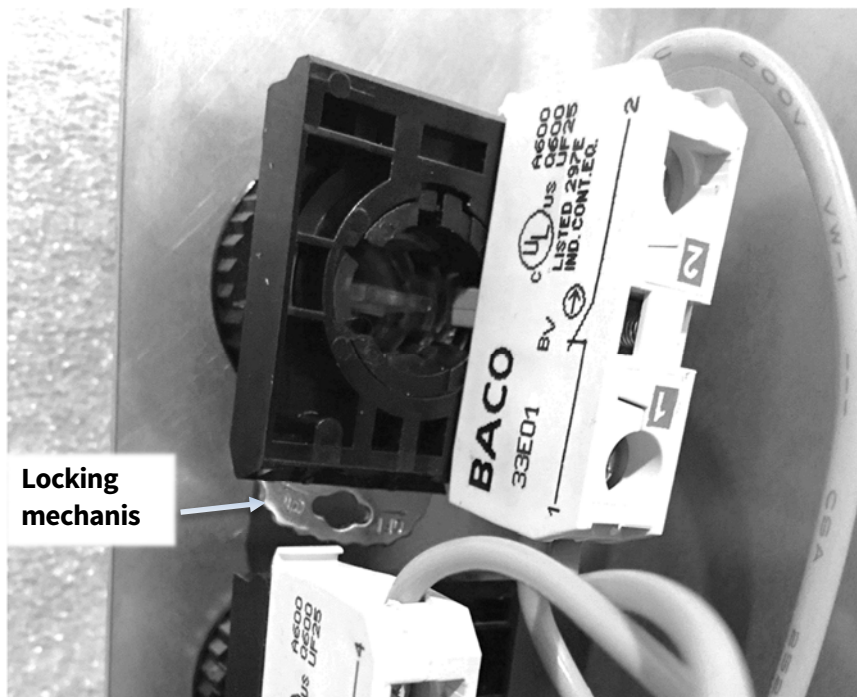

2. Undo the plastic nut holding the buttons to the chassis.



Note! Disconnect the electric power to the machine!

3. Press the button out of the hole. Note the cut-out in the chassis which is aligned with the small notch on the button.



Reassemble in reversed order.

Note! Disconnect the electric power to the machine!

Motor and lower gear box half

1. Remove the earth connections to the gearbox.

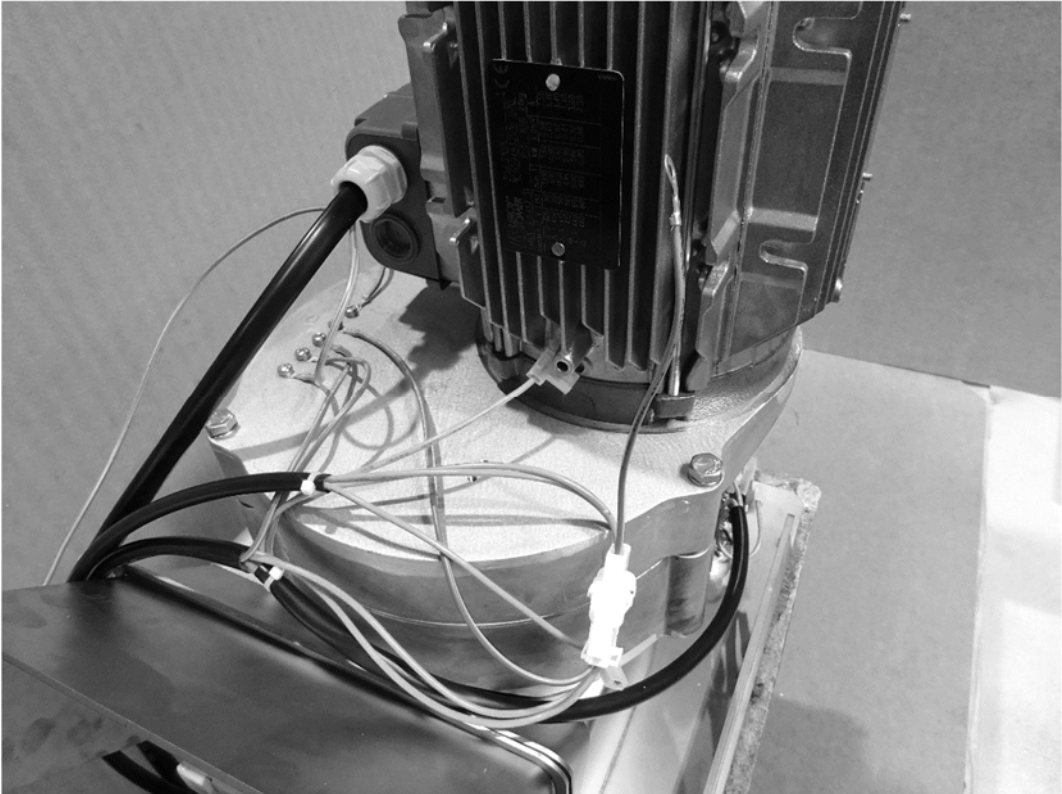

2. Remove the three hex head screws holding the gearbox together. Lift off the motor.

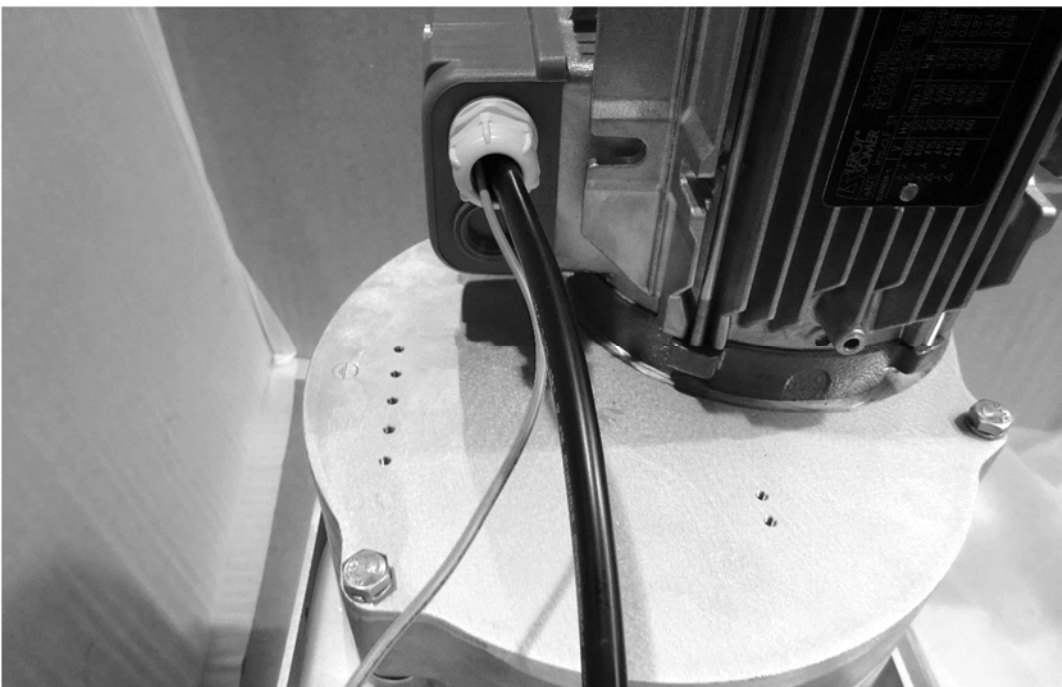

The motor is heavy and should be lifted straight up. Two persons are recommended for this step. Slightest dent on the teeth of any of the two gears will produce a knocking sound during operation. Take care not damaging the fan blades when putting the motor down.

Note! Disconnect the electric power to the machine!

3. Remove the screw holding the gear in place on the motor shaft.



4. Use a gear puller to remove the gear.

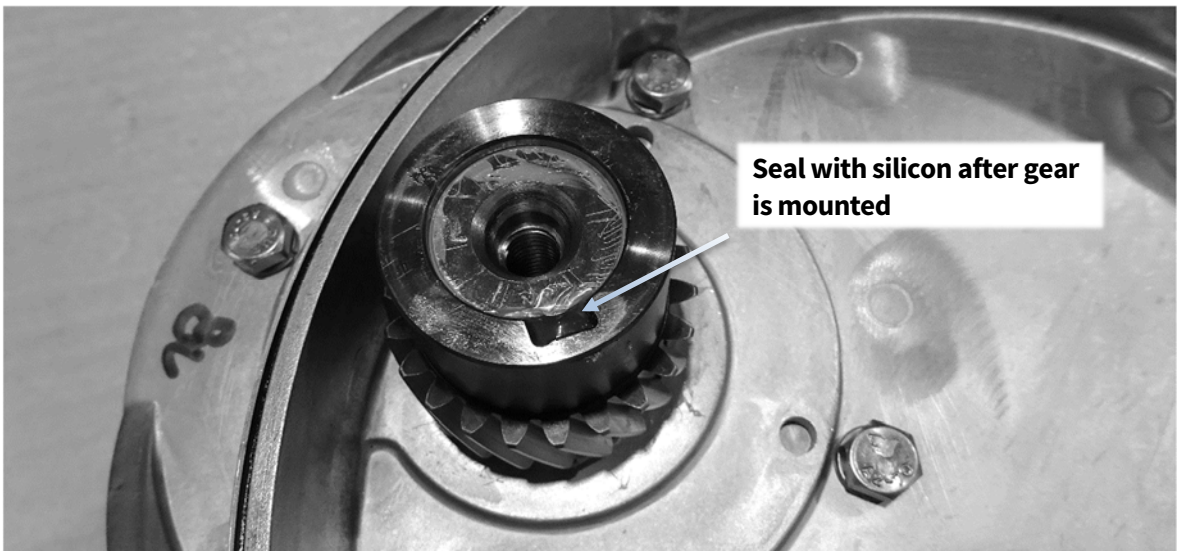

5. Remove the three hex head screws to separate the motor from the gearbox.

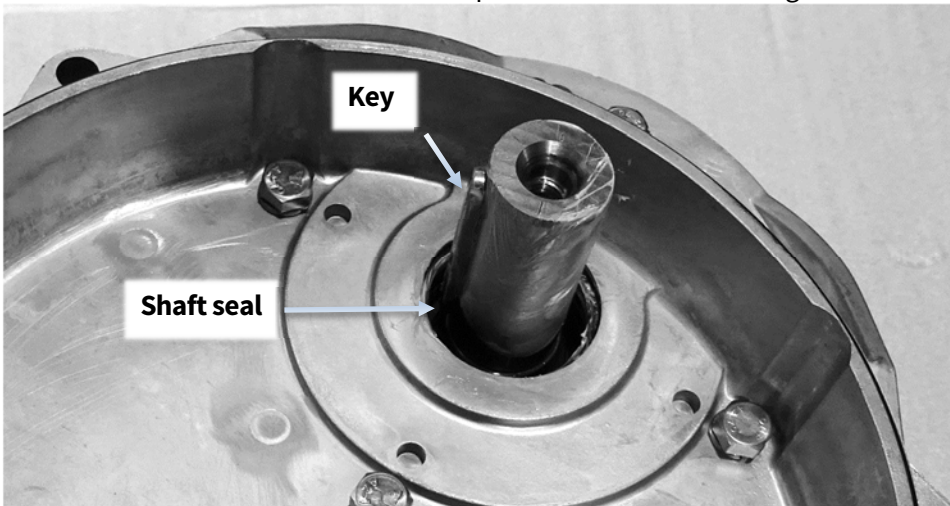

Note! Disconnect the electric power to the machine!

The seal is mounted from the other side and should be inserted with the spring towards the gears. Preferably it should be lubricated with the same grease as is used in the gearbox.

6. Motor removed.

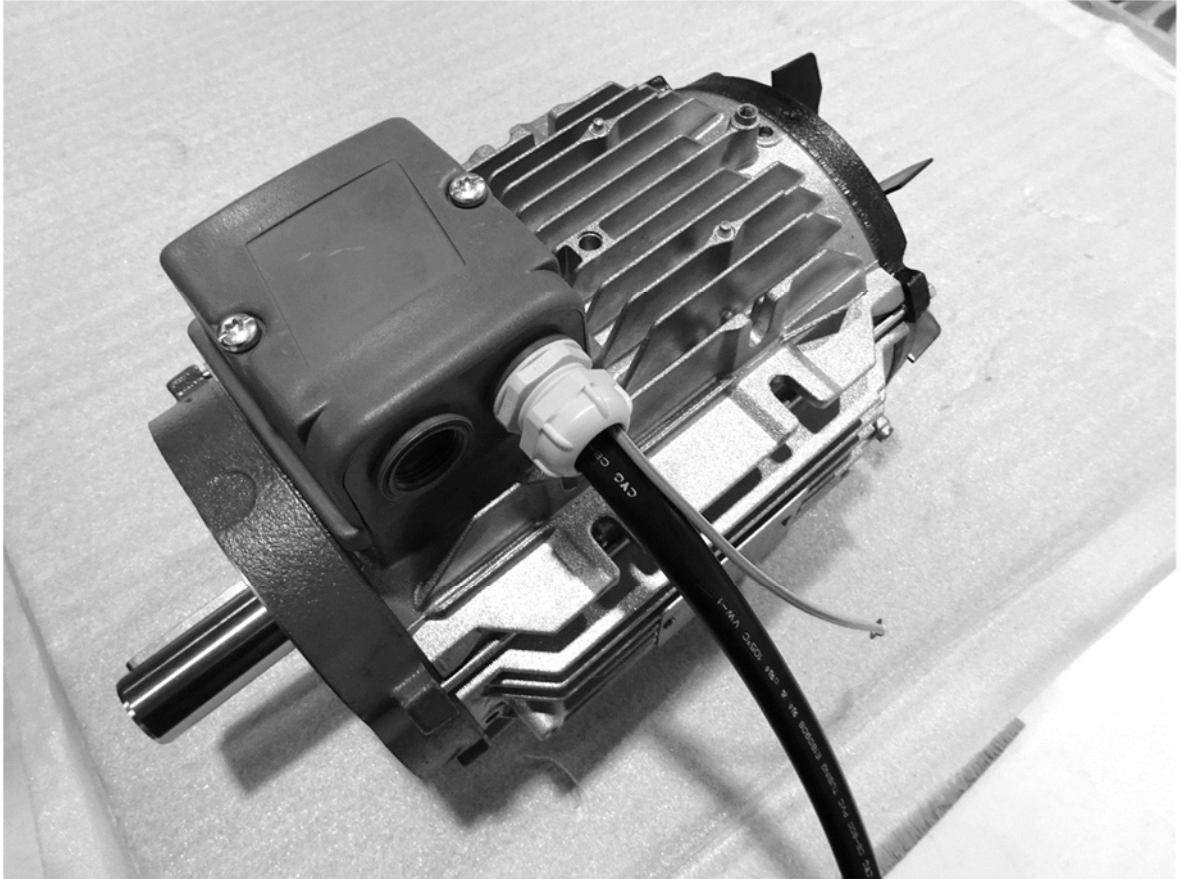

Reassemble in reversed order. Do not forget to seal the keyway with silicone on the motor once the small gear is mounted. See wiring diagram at www.hallde.com for internal wiring.

Note! Disconnect the electric power to the machine!

Upper gear box half

1. Remove the screw holding the gear to the knife shaft.

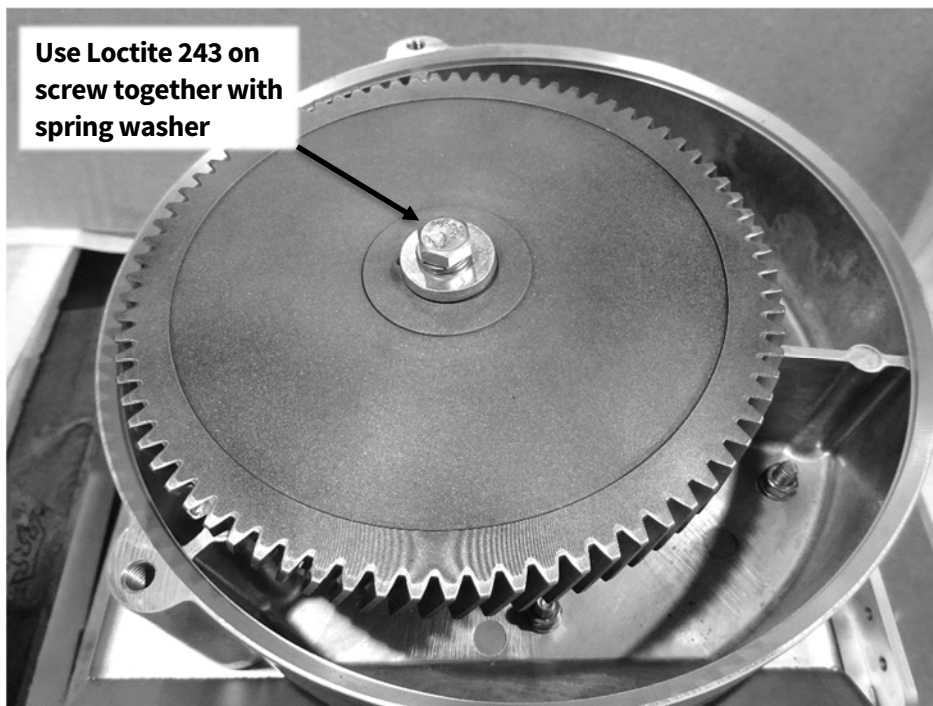

2. Gear removed.

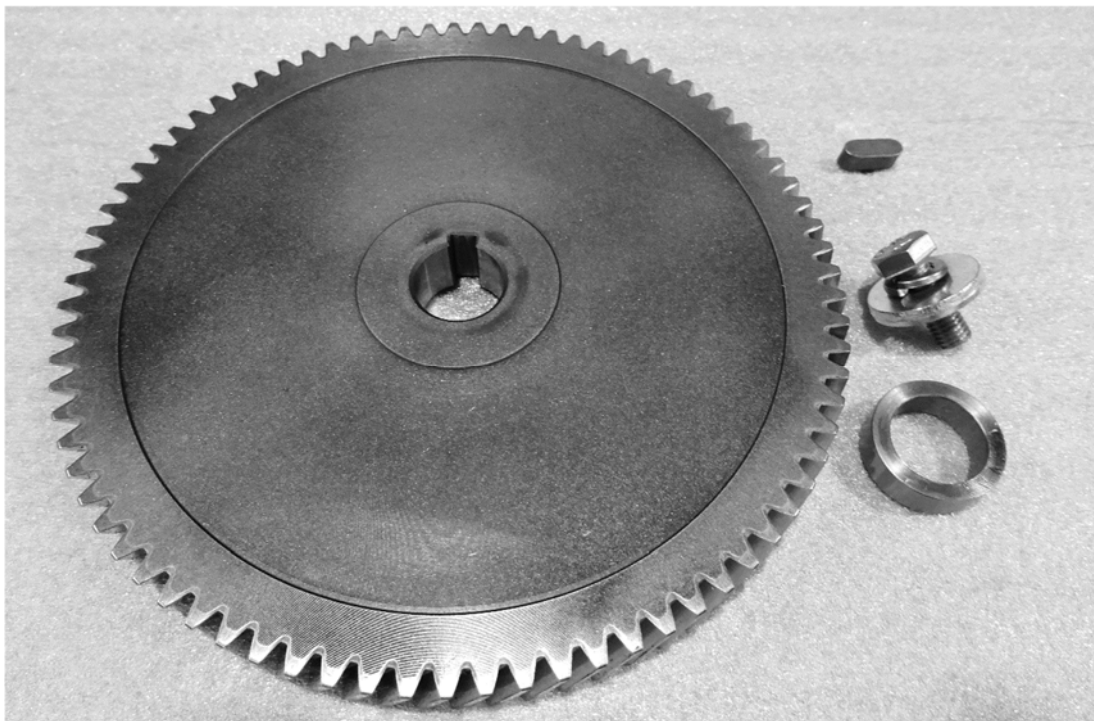

Reassemble in reversed order. Be sure to tighten the screw firmly.

Note! Disconnect the electric power to the machine!

Bearing house and shaft

1. The knife shaft can now be removed from the top. Remove the four hex head screws holding the bearings in place.

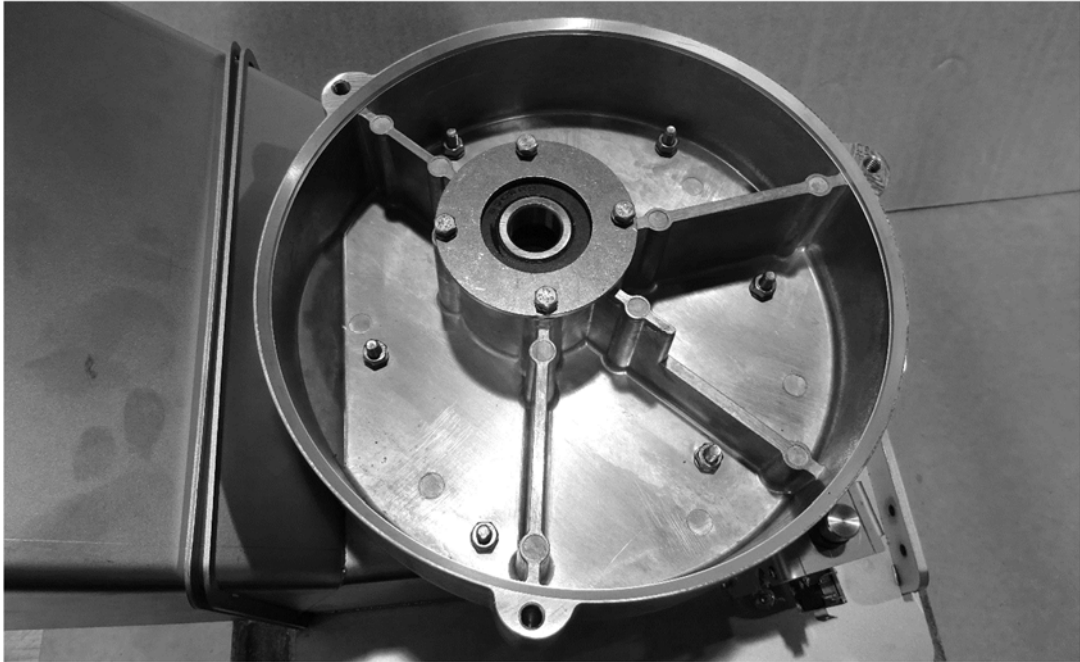

2. Bearing kit disassembled.



Note! Disconnect the electric power to the machine!

3. Remove the six nuts holding the gear box to the knife chamber.

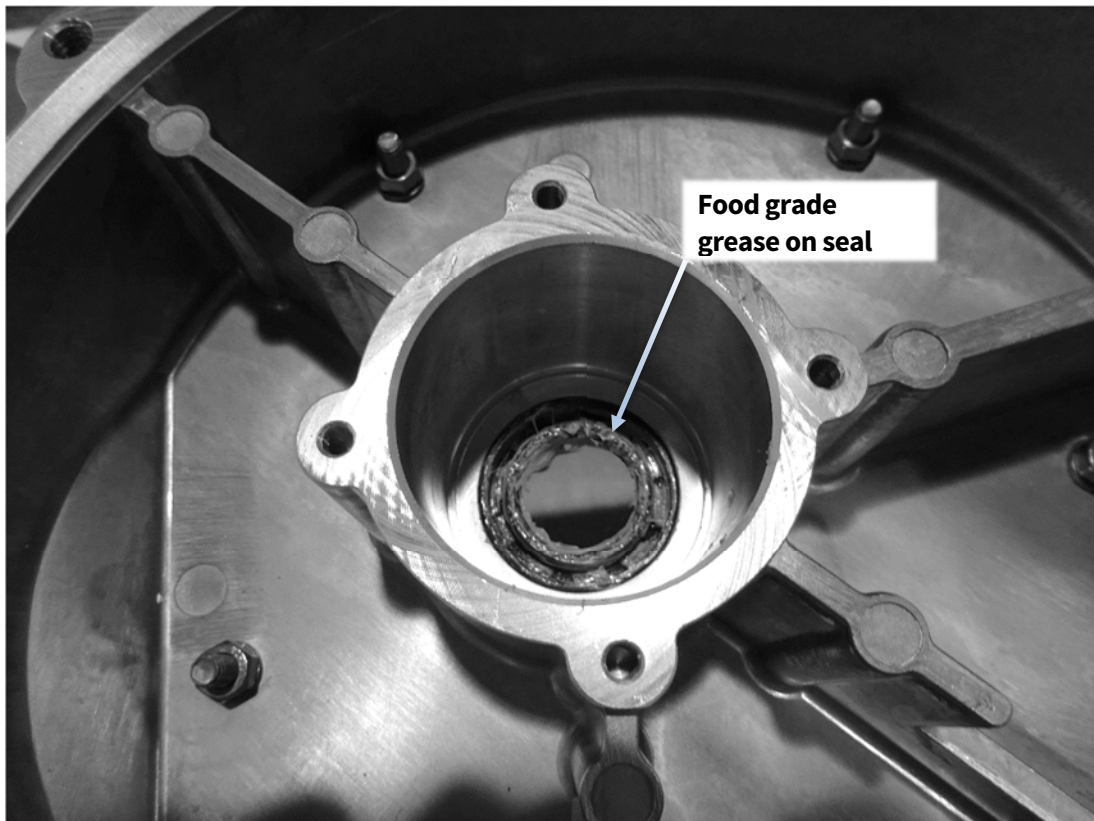

Reassemble in reversed order. Do not to overtighten the six nuts or dimples will form on the opposite side. Use a torque of maximum 6,5 Nm.

Note! Disconnect the electric power to the machine!

Micro switch unit

1. On the knife chamber, remove the micro switch unit by unplugging all electrical connections including the earth connection.



2. Remove the three nuts. Lift the unit off.



Note! Disconnect the electric power to the machine!

3. The flange is sealed against the knife chamber. Alternatively, silicone can be used.

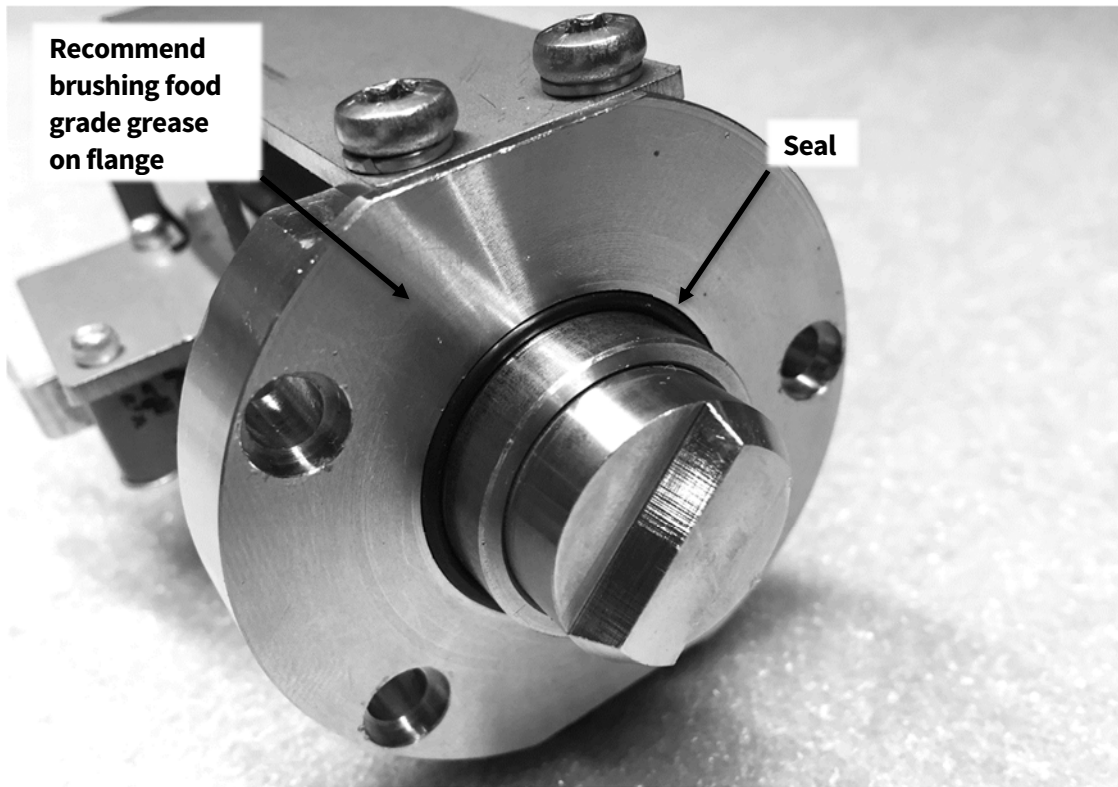

4. Compress the spring by pushing on the shaft. Insert a screwdriver in the hole at the other end of the shaft. Release the pressure and remove the four screws holding the bracket to the flange. Once the flange is taken off remove the screwdriver carefully as the spring is compressed and could eject the shaft. Take out the shaft and spring.

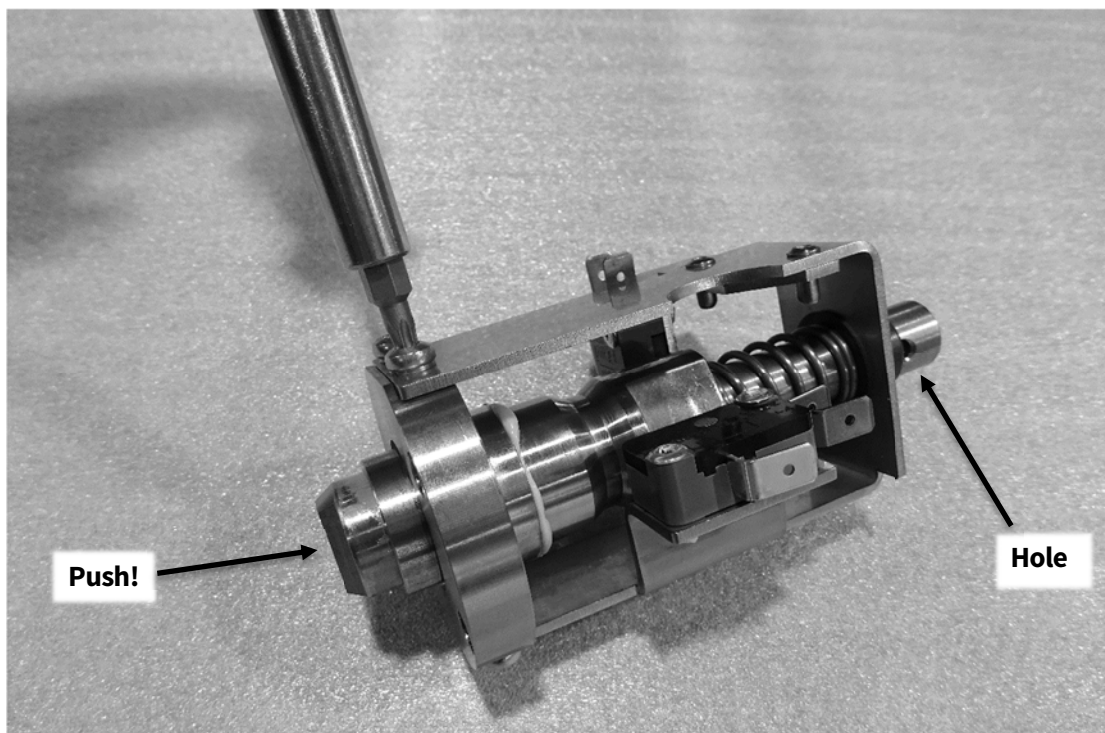

Note! Disconnect the electric power to the machine!

5. The micro switches are riveted to the bracket. Either replace the bracket with a complete bracket or sand down the rivets and install new micro switches. Use **aluminium** rivets or the housing of the switch will be damaged.

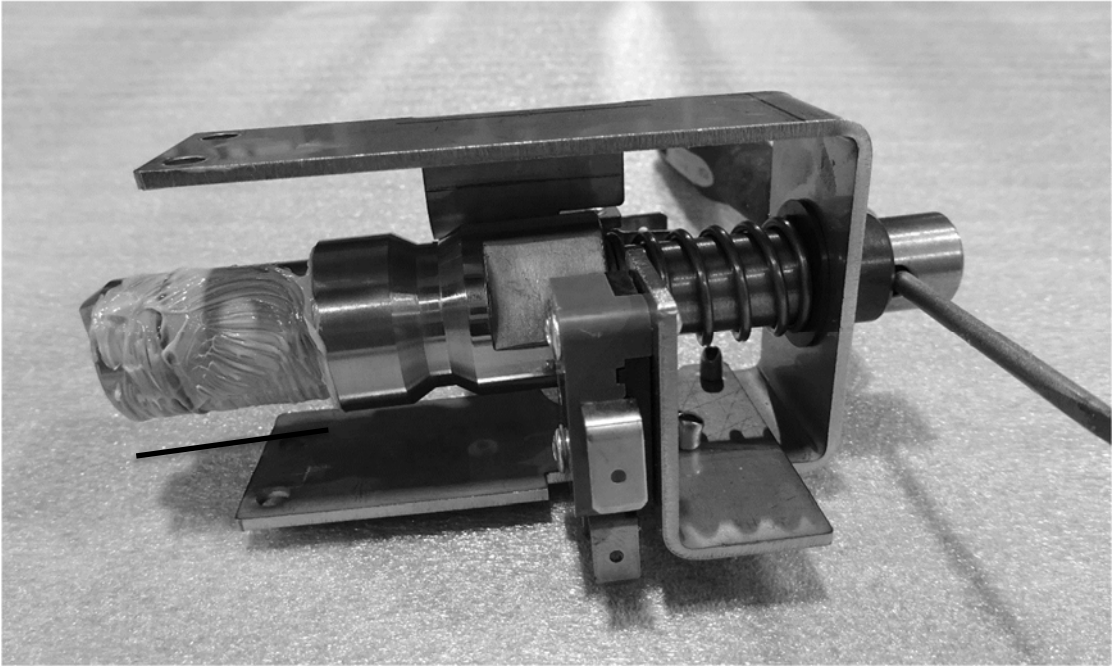

6. The shaft is lubricated according to picture below.

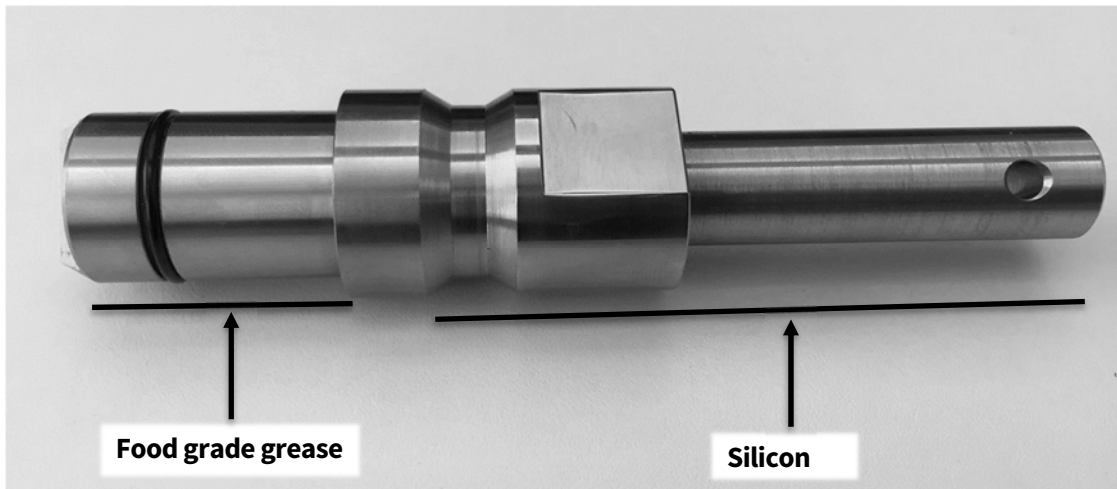

Note! Disconnect the electric power to the machine!

7. Completely disassembled micro switch unit.

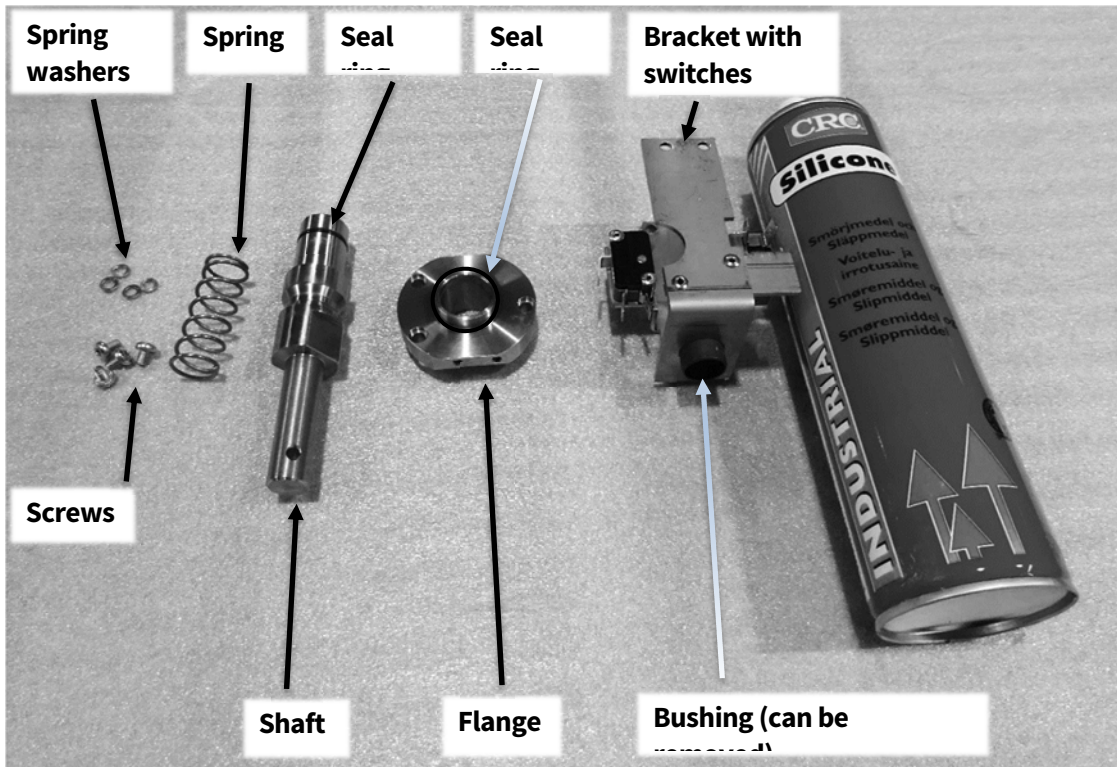

Reassemble in reversed order. Make sure that the flange is flat against the knife chamber to prevent water from entering. Remove seal ring on the shaft if worn out.

Important!

Before the shaft is inserted check that the surface on which the actuators glide on is smooth and free from burrs. When inserting the shaft with the spring be careful not to damage the actuators on the switches.

Always test the unit and assure the actuators are clearly triggered. The bracket holding the switch which is actuated by turning the shaft can be bent inwards to assure that the actuator on the switch is pushed far enough. Just after the switch is triggered (listen to the sound of the switch) make sure that the actuator continues to move inwards as the shaft is turned. Read chapter "Service procedures and Adjustments" in this manual.

Note! Disconnect the electric power to the machine!

Knife chamber

At this stage the disassembly is finished. When reassembling, remove any old silicone around the six screws and the middle hole. Seal the holes with fresh silicone by applying it around the base of the screws and the middle hole.

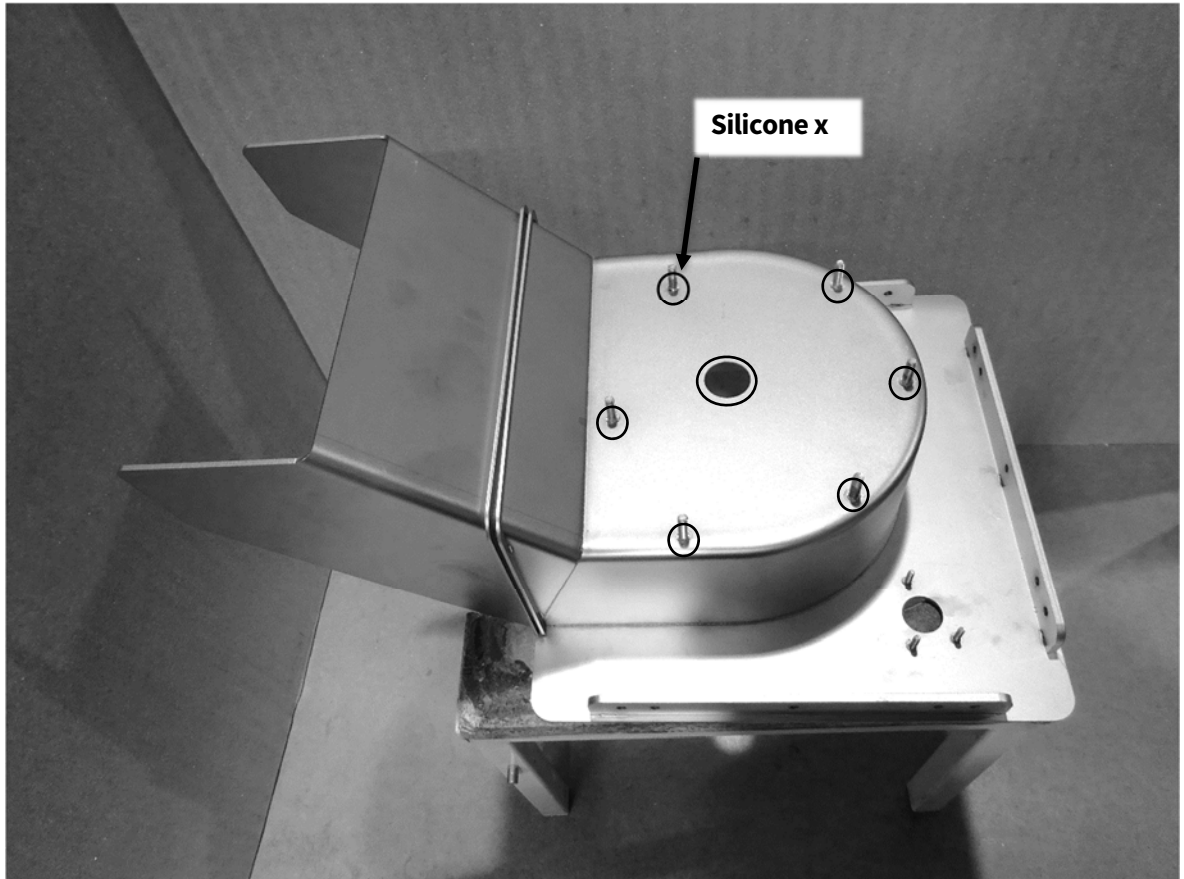

Advice:

When reassembling from this stage start with the micro switch unit. Make sure the flange sits tightly against the knife chamber (don't forget the seal). It's easier to connect the wires to the micro switches at this point.

Continue with the upper gearbox half. The gearbox can only be mounted one way. There is some play between the six holes in the gear box and the welded screws on the knife chamber. To centre the shaft correctly do the following:

1. Make sure that the gear box is placed flat on the knife chamber.
2. Fasten the six nuts and spring washers by hand.
3. Assemble the bearings and the bearing lid. Start with the biggest bearing then the spacer and lastly the small bearing. Fasten the lid with the screws.
4. From the top (cavity side), push the knife shaft through the bearings. This gives clearance between the shaft and the hole through the knife chamber. Now tighten the six nuts. Continue the assembly from there.

Note! Disconnect the electric power to the machine!

Service Procedures and Adjustments

Function and safety test

1. Remove decoring screw and cutting tools.
2. Connect food processor to the proper voltage source.
 1. Close feed cylinder and engage locking handle.
 2. Position pusher plate into the feed cylinder.
3. Press ON button and motor should start.
4. Press OFF button and motor should stop.
5. Press ON button, motor starts. Lift pusher plate out of feed cylinder and slowly rotate to the left.
 1. Motor should stop when the edge of pusher plate is no more than 4 cm from the inside edge of feed cylinder. If motor operates outside of this dimension, adjust the micro switch on the micro switch unit.
 2. Rotate the pusher plate over the cylinder. The motor should start when the edge of the pusher plate is 4 cm or less from the inside edge of feed cylinder.
6. With the motor running disengage the locking handle by pulling it off the feed cylinder. The machine should stop. Also check that the machine (while holding down the start button) starts after the locking handle has visibly lifted from its bottom position.

Electrical safety tests

If the machine has been opened the machine may need to undergo electrical safety tests.

1. An electric strength test should be done. From factory the machine is tested at 1.77 kV for 1 sec. The electric box and motor can be tested separately. Close the contactors when performing the test on the electric box. The combined result should not exceed 5 mA.
2. An earth continuity test should be done on the assembled machine. At 10 A and 12 V max resistance allowed is 0,2 Ω .

Electrical diagram

See user instructions and www.halld.com for applicable electric diagram.

Note! Disconnect the electric power to the machine!

Troubleshooting

SYMPTOM	POSSIBLE CAUSES
Motor will not start, feed cylinder is down, locking handle is up and pusher plate is in operating position.	<ol style="list-style-type: none">1. Check fuses.2. "Shaft stand" and "micro switch unit" not aligned properly.3. No voltage to machine.4. Transformer is faulty.5. Over current protection is not set to auto reset.6. OFF switch malfunction.7. ON switch malfunction.8. A micro switch has oxidized contact points.9. Contactor malfunction.10. Motor malfunction. Open circuit in winding.
Motor does not stop when pusher plate is raised out of feed hopper and rotated past the 4 cm maximum allowable feed cylinder opening.	<ol style="list-style-type: none">1. Micro switch in micro switch unit is loose or worn down.
Motor stops during use, restarts after a couple of minutes.	<ol style="list-style-type: none">1. Overcurrent protection is triggered.<ol style="list-style-type: none">a. Excessive feed pressure on pusher plate or pneumatic feeder (max 5.5 bar).b. Tools worn out.c. Incorrect speed set either on machine or pneumatic feeder in relation to cutting tool capacity. Thin or small cuts process less food over time than big slices. Single knife process less food over time than dual knives.2. Thermal overload protection in motor triggered or is malfunctioning. The machine is working at the limits of its thermal capacity. See point 1 above.

Note! Disconnect the electric power to the machine!

Low output or poor cutting.	<ol style="list-style-type: none">1. Wrong combination of cutting tools used.2. Cutting tools dull.3. Decoring screw not installed.4. Excessive feed pressure on pusher plate.5. Incorrect speed selected for either pneumatic feeder or machine.6. Ejector plate not used.
-----------------------------	--