



MANUFACTURER

HALLDE

MODEL

RG-250 

PRODUCT DESCRIPTION

Vegetable Preparation Machine, process up to 8 kg/minute.

ORIGIN

Sweden

SPECIFICATION

SPECIFICATION TEXT	Vegetable preparation machine with leaning design and full moon feed cylinder, made to process 10 kg/minute or 100-1000 portions/day. The machine's pusher plate, knife housing and feed piston are made of aluminium and have an organic polymer coating. The organic coating allows these parts to be cleaned in a dishwasher, "diwash". The pusher plate has a loop-shaped, stainless steel handle and a 56-mm diameter feeder tube. Pusher plate with system for leverage effect. Four-litre feed cylinder with 55 mm inner wall. All removable parts of the RG-250 diwash are dishwasher safe. The associated cutting tools are 185-mm in diameter, made of stainless steel/aluminium/acetate, have exchangeable knives/plates and are dishwasher safe. The motor rotates the cutting blade clockwise and directly, without intermediate belts.				
FUNCTION	Machine for slicing, dicing, shredding, grating, cutting julienne and French fries. Processes fruit, vegetables, dry bread, cheese, nuts, mushrooms, etc.				
CAPACITY	Up to 800 portions/day and up to 8 kg/minute. 4 liter feed cylinder, 56 mm tube feeder for elongated products.				
MATERIAL	Machine base: aluminium. Knife housing, feed cylinder and feed piston: aluminium with organic, polymer coating. Handle: stainless steel. Cutting tools: stainless steel/aluminium/fibreglass-reinforced polyamide. Ejector plate: acetate.				
MOTOR	0.55 kW. One-speed (350 rpm) 120 V, 1-phase, 60 Hz. 220-240 V, 1-phase, 50/60 Hz. 230-240 V, 3-phase, 50 Hz. 400 V, 3-phase, 50/60 Hz. 440 V, 3-phase, 60 Hz. Thermal protection, Planetary gearing.				
POWER SUPPLY	Earthed, single phase, 10 A / three phase, 16 A. Fuse: 10 A delayed action fuse.				
STANDARDS	EN 1678+A1:2010. NSF/ANSI Standard 8.				
RECOMMENDED CUTTING TOOL PACKAGES	INCLUDING			NET WEIGHT	
	<ul style="list-style-type: none"> • 4-pack Cutting Tools <ul style="list-style-type: none"> - Slicer 1.5 mm - Slicer 4 mm - Grater/Shredder 2 mm - Grater/Shredder 8 mm 			2 kg	
<ul style="list-style-type: none"> • 7-pack Cutting Tools <ul style="list-style-type: none"> - Slicer 1.5 mm - Slicer 4 mm - Slicer 10 mm - Grater/Shredder 2 mm - Grater/Shredder 8 mm - Julienne Cutter 4x4 mm - Dicing Grid 10x10 mm 			3,5 kg		
WEIGHT/VOLUME	CONTENT	NET WEIGHT	PACKAGES	FREIGHT WEIGHT	FREIGHT VOLUME
	RG-250 diwash Machine	22 kg	1	25 kg	0.183 m ³
	Container Trolley incl. GN 1/1 container	9 kg	1	12.5 kg	0.15 m ³
Machine Table incl. GN 1/1 container	13,25 kg	1	14,5 kg	0,8 m ³	
SAFETY	2014/30/EU, 2014/35/EU, 2006/42/EG, 2011/65/EU, no 10/2011				
DIRECTIVE AND REGULATION	CE approved. Two safety switches, machine safety: IP44, push buttons safety: IP65.				

DRAWINGS

The drawings below can be downloaded at hallde.com.

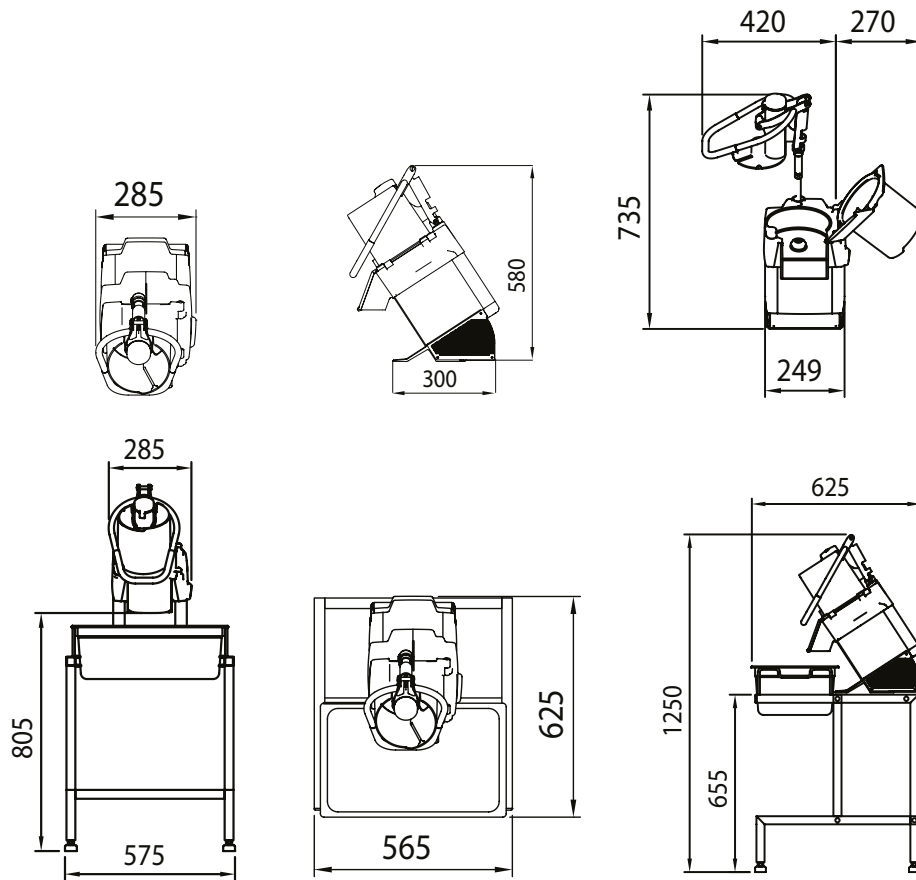

Продажа и обслуживание оборудования Halldé:



ChefStore LLC, ООО «ШефСтор»

+7 (495) 212-18-44, +7 (800) 500-16-87

office@chefstore.ru

www.chefstore.ru